

BGA8V1BN6

Low Noise Amplifier for LTE Band 42 and Band 43

Features

- Operating frequencies: 3.3 - 3.8 GHz
- Insertion power gain: 15.0 dB
- Insertion Loss in bypass mode: 5.3 dB
- Low noise figure: 1.2 dB
- Low current consumption: 4.2 mA
- Multi-state control: OFF-, bypass- and high gain-Mode
- Ultra small TSNP-6-2 leadless package
- RF input and RF output internally matched to 50 Ohm
- No external components necessary

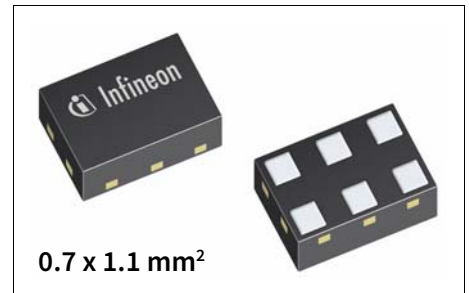

Application

The LTE data rate can be significantly improved by using the Low Noise Amplifier. The integrated bypass function increases the overall system dynamic range and leads to more flexibility in the RF front-end.

In high gain mode the LNA offers best Noise Figure to ensure high data rates even on the LTE cell edge. Closer to the basestation the bypass mode can be activated reducing current consumption.

Product Validation

Qualified for industrial applications according to the relevant tests of JEDEC47/20/22.

Block diagram

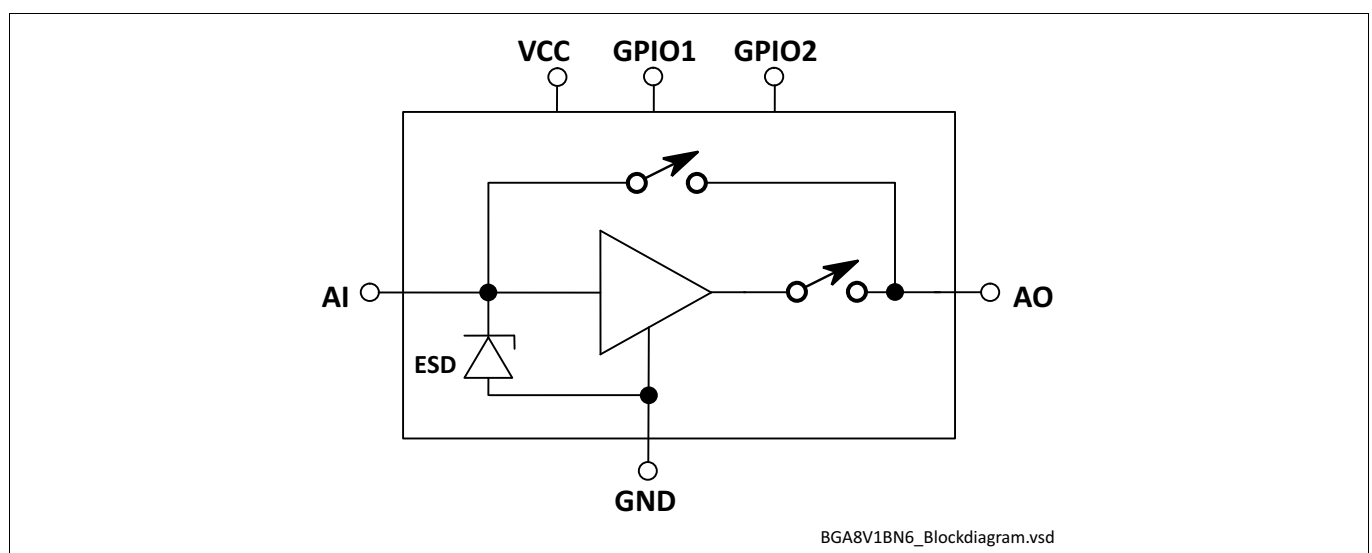



Table of Contents

Table of Contents

	Table of Contents	2
1	Features	3
2	Maximum Ratings	5
3	Electrical Characteristics	6
4	Application Information	7
5	Package Information	8

Features

1 Features

- Insertion power gain: 15.0 dB
- Insertion Loss in bypass mode: 5.3 dB
- Low noise figure: 1.2 dB
- Low current consumption: 4.2 mA
- Operating frequencies: 3.3 - 3.8 GHz
- Multi-state control: OFF-, bypass- and high gain-Mode
- Supply voltage: 1.6 V to 3.1 V
- Ultra small TSNP-6-2 leadless package (footprint: 0.7 x 1.1 mm²)
- B9HF Silicon Germanium technology
- RF input and RF output internally matched to 50 Ohm
- No external SMD components necessary
- 2kV HBM ESD protection (including AI-pin)
- Pb-free (RoHS compliant) package

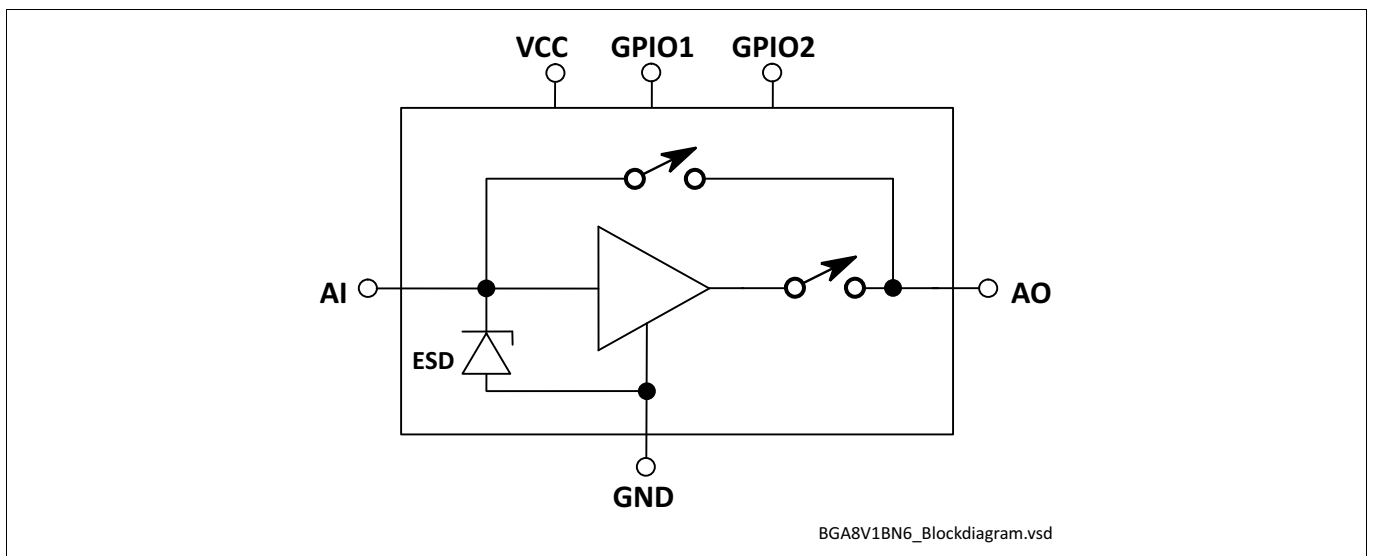

Figure 1 Block Diagram

Product Name	Marking	Package
BGA8V1BN6	X	TSNP-6-2

Features

Description

The BGA8V1BN6 is a front-end low noise amplifier for LTE which covers a wide frequency range from 3.3 GHz to 3.8 GHz. The LNA provides 15.0 dB gain and 1.2 dB noise figure at a current consumption of 4.2 mA in the application configuration described in **Chapter 4**. In bypass mode the LNA provides an insertion loss of 5.3 dB. The BGA8V1BN6 is based upon Infineon Technologies' B9HF Silicon Germanium technology. It operates from 1.6 V to 3.1 V supply voltage. The device features a multi-state control (OFF-, bypass- and high gain-Mode).

Pin Definition and Function

Table 1 Pin Definition and Function

Pin No.	Name	Function
1	GPIO2	Control pin 2
2	VCC	DC supply
3	AO	LNA output
4	GPIO1	Control pin 1
5	GND	Ground
6	AI	LNA input

Control Table

Table 2 Control Table

	GPIO1	GPIO2
OFF	Low	Low
	High	Low
Bypass mode	Low	High
High gain mode	High	High

Maximum Ratings

2 Maximum Ratings

Table 3 Maximum Ratings

Parameter	Symbol	Values			Unit	Note or Test Condition
		Min.	Typ.	Max.		
Voltage at pin VCC	V_{CC}	-0.3	-	3.6	V	1)
Voltage at pin AI	V_{AI}	-0.3	-	0.9	V	-
Voltage at pin AO	V_{AO}	-0.3	-	$V_{CC} + 0.3$	V	-
Voltage at GPIO pins	V_{GPIO}	-0.3	-	$V_{CC} + 0.3$	V	-
Voltage at pin GND	V_{GND}	-0.3	-	0.3	V	-
Current into pin VCC	I_{CC}	-	-	16	mA	-
RF input power	P_{IN}	-	-	+25	dBm	-
Total power dissipation, $T_S < 148\text{ °C}^2)$	P_{tot}	-	-	60	mW	-
Junction temperature	T_J	-	-	150	°C	-
Ambient temperature range	T_A	-40	-	85	°C	-
Storage temperature range	T_{STG}	-65	-	150	°C	-
ESD capability all pins	V_{ESD_HBM}	-	-	2000	V	according to JS-001

- 1) All voltages refer to GND-Node unless otherwise noted
- 2) T_S is measured on the ground lead at the soldering point

Attention: *Stresses above the max. values listed here may cause permanent damage to the device. Maximum ratings are absolute ratings; exceeding only one of these values may cause irreversible damage to the integrated circuit. Exposure to conditions at or below absolute maximum rating but above the specified maximum operation conditions may affect device reliability and life time. Functionality of the device might not be given under these conditions.*

Electrical Characteristics

3 Electrical Characteristics

Table 4 Electrical Characteristics¹⁾
 $T_A = 25\text{ °C}$, $V_{CC} = 2.8\text{ V}$, $V_{GPIOx,ON} = 2.8\text{ V}$, $V_{GPIOx,OFF} = 0\text{ V}$, $f = 3300 - 3800\text{ MHz}$

Parameter	Symbol	Values			Unit	Note or Test Condition
		Min.	Typ.	Max.		
Supply voltage	V_{CC}	1.6	2.8	3.1	V	–
Control voltages	V_{GPIOx}	1.0	–	V_{CC}	V	High
		0	–	0.4	V	Low
Supply current	I_{CC}	–	4.2	5.2	mA	High gain mode
		–	85	120	μA	Bypass mode
		–	0.1	2	μA	OFF-Mode
Insertion power gain $f = 3500\text{ MHz}$	$ S_{21} ^2$	13.0	15.0	17.0	dB	High gain mode
		-6.8	-5.3	-3.8	dB	Bypass mode
Noise figure ²⁾ $f = 3500\text{ MHz}$, $Z_S = 50\ \Omega$	NF	–	1.2	1.7	dB	High gain mode
		–	5.3	6.8	dB	Bypass mode
Input return loss ³⁾ $f = 3500\text{ MHz}$	RL_{IN}	10	15	–	dB	High gain mode
		10	16	–	dB	Bypass mode
Output return loss ³⁾ $f = 3500\text{ MHz}$	RL_{OUT}	8	11	–	dB	High gain mode
		3	5	–	dB	Bypass mode
Reverse isolation ³⁾ $f = 3500\text{ MHz}$	$1/ S_{12} ^2$	20	28	–	dB	High gain mode
		6.8	5.3	–	dB	Bypass mode
Transient time ⁴⁾⁶⁾	t_S	–	0.3	3	μs	High gain- to bypass-mode
		–	3	5	μs	Bypass- to High gain-mode
Inband input 1dB-compression point, $f = 3500\text{ MHz}$ ³⁾	IP_{1dB}	-19	-15	–	dBm	High gain mode
		-7	-3	–	dBm	Bypass mode
Inband input 3 rd -order intercept point ³⁾⁵⁾ $f_1 = 3500\text{ MHz}$, $f_2 = f_1 \pm 1\text{ MHz}$	IIP_3	-8	-3	–	dBm	High gain mode
		1	6	–	dBm	Bypass mode
Phase discontinuity between ON- and bypass-mode ³⁾		-6	–	6	°	Part to part variation after compensation in Base Band with constant value
Stability ⁶⁾	k	> 1	–	–		$f = 20\text{ MHz} \dots 10\text{ GHz}$

1) Based on the application described in chapter 4

2) PCB losses are subtracted

3) Verification based on AQL; not 100% tested in production

4) To be within 1 dB of the final gain

5) Input power HG = -30 dBm for each tone; Input power BP = -10 dBm for each tone

6) Guaranteed by device design; not tested in production

Application Information

4 Application Information

Application Board Configuration

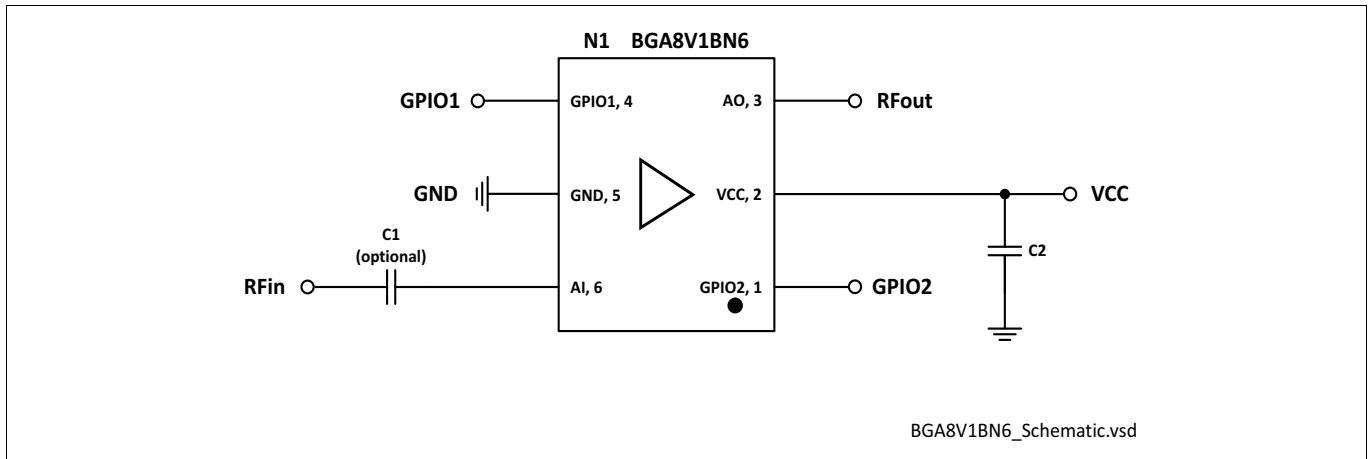

Figure 2 Application Schematic BGA8V1BN6

Table 5 Bill of Materials

Name	Value	Package	Manufacturer	Function
C1 (optional)	≥ 1nF	0402	Various	Input matching
C2	≥ 1nF	0402	Various	RF bypass ¹⁾
N1	BGA8V1BN6	TSNP-6-2	Infineon	SiGe LNA

1) RF bypass recommended to mitigate power supply noise

Note: No external DC blocking capacitor at RFin is required in typical applications as long as no DC is applied.

A list of all application notes is available at <http://www.infineon.com/ltelna>

Package Information

5 Package Information

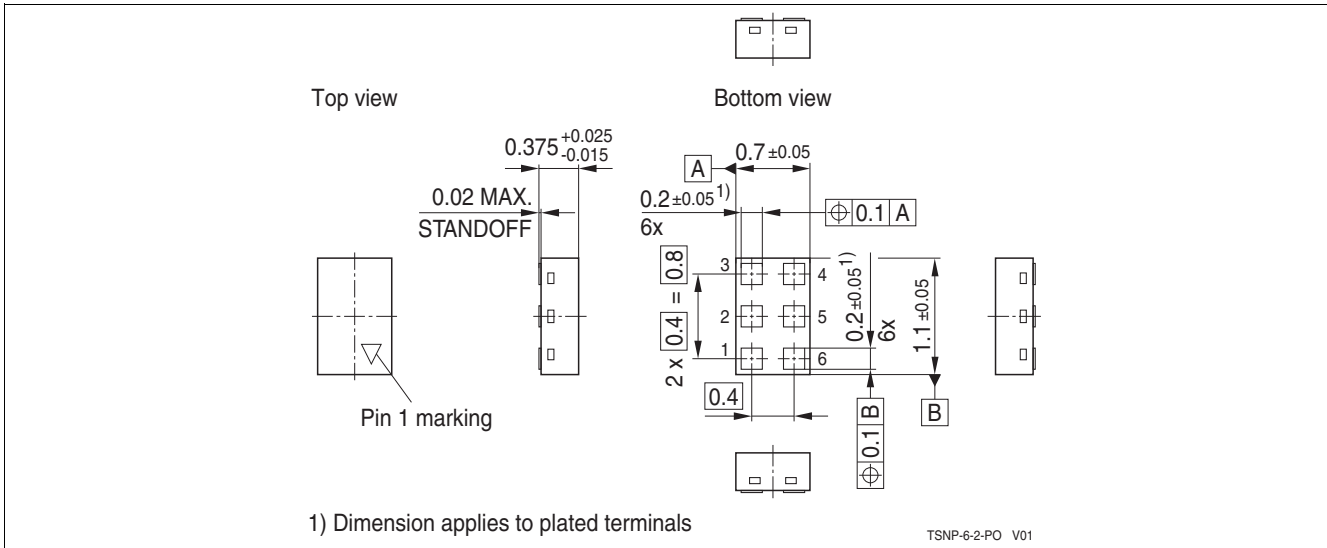

Figure 3 TSNP-6-2 Package Outline (top, side and bottom views)

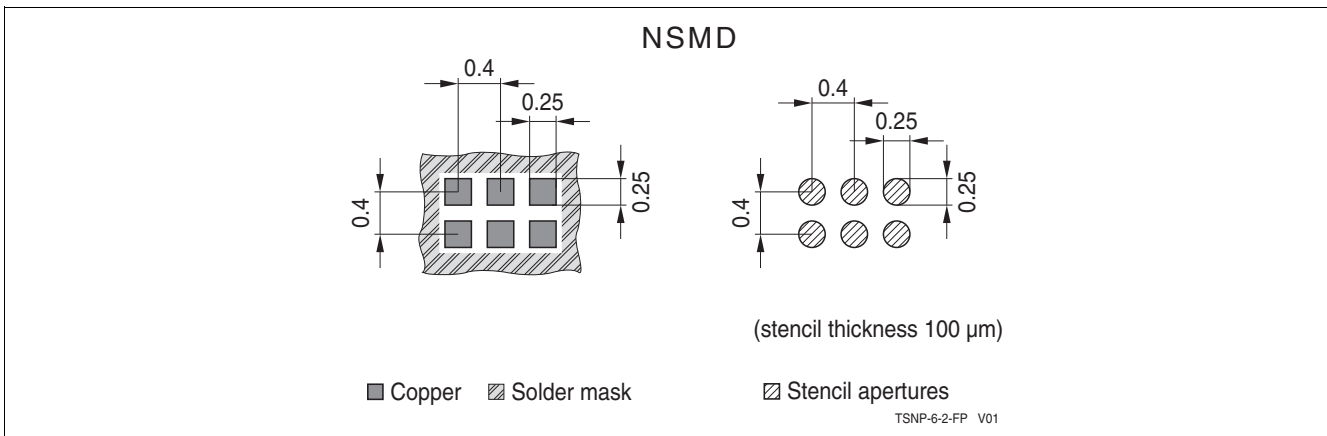

Figure 4 Footprint Recommendation TSNP-6-2

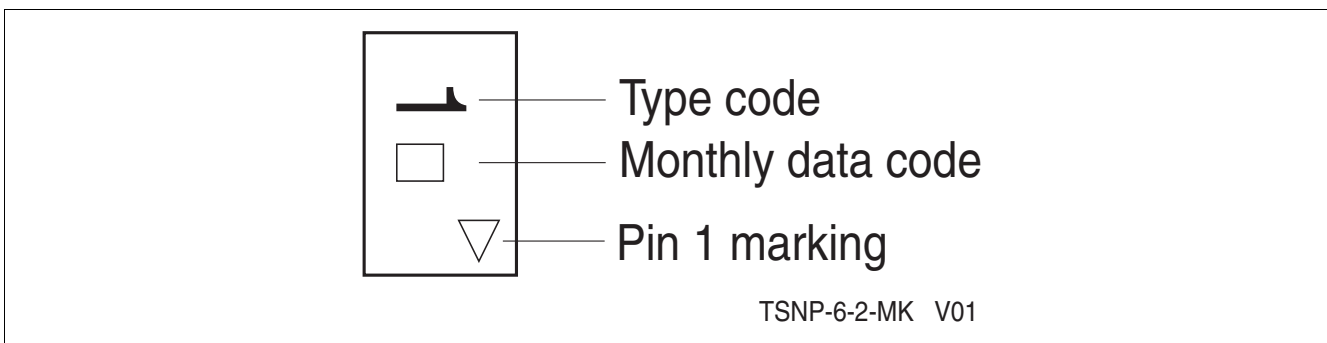

Figure 5 Marking Layout (top view)

BGA8V1BN6
Low Noise Amplifier for LTE Band 42 and Band 43

Package Information

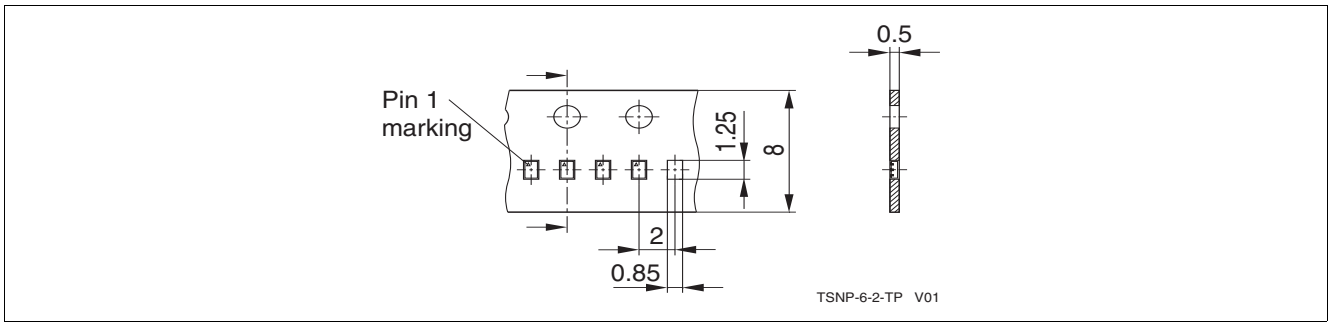

Figure 6 Tape & Reel Dimensions (reel diameter 180 mm, pieces/reel 15000)

Revision History

Page or Item	Subjects (major changes since previous revision)
Revision 3.3 (min/max), 2017-09-14	
5	Update max. RF input power
11	Update trademark information

Other Trademarks

All referenced product or service names and trademarks are the property of their respective owners.

Edition 2017-09-14

Published by

Infineon Technologies AG

81726 Munich, Germany

© 2017 Infineon Technologies AG.

All Rights Reserved.

Do you have a question about any aspect of this document?

Email: erratum@infineon.com

Document reference

Doc_Number

IMPORTANT NOTICE

The information given in this document shall in no event be regarded as a guarantee of conditions or characteristics ("Beschaffheitsgarantie").

With respect to any examples, hints or any typical values stated herein and/or any information regarding the application of the product, Infineon Technologies hereby disclaims any and all warranties and liabilities of any kind, including without limitation warranties of non-infringement of intellectual property rights of any third party.

In addition, any information given in this document is subject to customer's compliance with its obligations stated in this document and any applicable legal requirements, norms and standards concerning customer's products and any use of the product of Infineon Technologies in customer's applications.

The data contained in this document is exclusively intended for technically trained staff. It is the responsibility of customer's technical departments to evaluate the suitability of the product for the intended application and the completeness of the product information given in this document with respect to such application.

For further information on technology, delivery terms and conditions and prices, please contact the nearest Infineon Technologies Office (www.infineon.com).

WARNINGS

Due to technical requirements products may contain dangerous substances. For information on the types in question please contact your nearest Infineon Technologies office.

Except as otherwise explicitly approved by Infineon Technologies in a written document signed by authorized representatives of Infineon Technologies, Infineon Technologies' products may not be used in any applications where a failure of the product or any consequences of the use thereof can reasonably be expected to result in personal injury.